



**SAFE  
OWNER'S  
MANUAL**

SERIAL NO. \_\_\_\_\_

INTEGRITY — moral or ethical strength, the quality of being honest, the condition of being free from defects or flaws.

This is part of the Cannon Safe promise. We believe that you, the customer, have the right to expect “real security at affordable pricing” with unquestioned quality, to expect a warranty that does what it says and doesn’t need to be upgraded, and to expect that a customer can call and get answers, help or direction by knowledgeable safe technicians – people who have the authority to fix any Cannon Safe issue on the spot.

We started the company with a set of values, which are: (1) to produce the best product at the most competitive price and (2) to provide safe and meaningful employment while being environmentally friendly – hence we developed a manufacturing system that rewards productivity and safety.

Cannon Safe has been the pioneer in this industry. Most of our innovations have been ridiculed, but shortly after, copied – but never to the same quality or standard: composite doors, unibody construction and triple-hard plate, to name a few.

We believe a home security safe is a very permanent investment, and those who choose to secure personal items, family heirlooms, collectibles, money, or firearms should have peace of mind, knowing that these items are in a secure environment.

Thank you in advance for your consideration of our product. May it bring you many years of service and peace of mind.

Steven J. Baker  
President

# **DO NOT LOCK THIS IN YOUR SAFE**

**SERIAL NUMBER**

---

**PURCHASED AT**

---

**DATE**

---

**Cannon Safe Company  
216 South 2nd Ave.  
Bldg. 932  
San Bernardino, CA 92408  
[www.cannonsafe.com](http://www.cannonsafe.com)**

**4th Edition**

## INDEX

---

<b>Serial Number Information</b>	<b>page 1</b>
<b>Warranty</b>	<b>page 3</b>
<b>How to Open</b>	<b>page 5</b>
<b>Remove from Pallet</b>	<b>page 5</b>
<b>Interior Setup</b>	<b>page 7</b>
<b>Door Adjustment</b>	<b>page 8</b>
<b>Types of Electronic Locks</b>	<b>page 9</b>
<b>Using the LaGard Basic</b>	<b>page 10</b>
<b>Using the KABA MAS</b>	<b>page 12</b>
<b>Using the LaGard Access</b>	<b>page 14</b>
<b>Using the Mechanical Lock</b>	<b>page 17</b>
<b>Most Common Questions</b>	<b>page 18</b>
<b>Who to Call</b>	<b>page 20</b>
<b>Safe Accessories</b>	<b>page 20</b>
<b>Certificate of Compliance</b>	<b>page 21</b>
<b>Quick draw Gun Rack</b>	<b>page 22</b>
<b>Firearms Records</b>	<b>pages 23-44</b>



## CANNON LIFETIME WARRANTY

This Cannon Safe carries a lifetime warranty. It is warranted against defects in workmanship and materials also against damage by attempted break-in or actual break-in and fire.

In order to obtain service under this Warranty purchaser must provide Cannon Safe, Inc., with proof of purchase and police or fire department report. Cannon Safe, Inc., may, at its discretion, repair or replace any defective or damaged part or replace the defective or damaged safe. Whenever possible the safe will be repaired locally. Cannon Safe, Inc., at its discretion may require the safe to be returned to the factory. This being the case Cannon Safe, Inc., will at its expense have the safe opened and will pay for the freight to the factory and returned. The purchaser will have the safe packaged and palletized and available for a curbside pick up at their expense. The Warranty does not cover labor costs for removal or installation of the safe and contents. Personal property in the safe is not covered.

The obligation Cannon Safe, Inc., has under this Warranty is contingent upon proper installation and use of the safe, and shall not apply to parts or safes which have been misused, neglected, or put in unusual or extreme environments. Modifying or tampering with the safe, which might affect the product's use, voids the Warranty.

Without limit, this Warranty specifically excludes any liability for defects or damage caused by, or aggravated by, the use of unauthorized parts. Upon delivery, purchaser must promptly notify Cannon Safe Inc., of any defect. Purchaser's remedies are limited solely to repair, or replacing parts and are at the discretion of Cannon Safe, Inc.

Mechanical locks carry a lifetime warranty for parts and three years for labor. Electronic locks carry a lifetime warranty for parts and five years for labor.

This Warranty only applies to safes located in the continental United States.

This Warranty is given in place of all other warranties and assurances, whether expressed or implied, including but not limited to matters of quality, fitness for purpose, or merchantability and Cannon Safe, Inc., accepts no liability, under any circumstances whatsoever, for any incidental or consequential damage or loss suffered by anyone as a result of using or being unable to use the safe.

# UPON DELIVERY - HOW TO OPEN

---

## Electronic Lock

All safes leave the factory with the same combination.

Enter **1,2,3,4,5,6**

Turn handle or hub counter-clockwise to open. Spokes for handle are inside safe.

## SPOKES ARE LOCATED INSIDE SAFE

## Mechanical Lock

Using the key, turn key to the right; (clock-wise).

Turn dial to right, should stop about 90.

Turn handle or hub clock-wise to open.

## BE SURE TO TRY COMBINATION BEFORE CLOSING DOOR

For Complete Lock Operations – See Pages 9 thru 17

## TO REMOVE FROM PALLET

---

The safe is bolted to the pallet with two bolts located in opposite corners.

There are many ways to remove your safe from the pallet. However, we **STRONGLY ADVISE** that you hire a professional who has the appropriate knowledge and equipment to properly remove from the pallet.

## REMEMBER SAFE IS TOP HEAVY

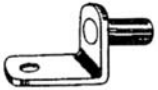
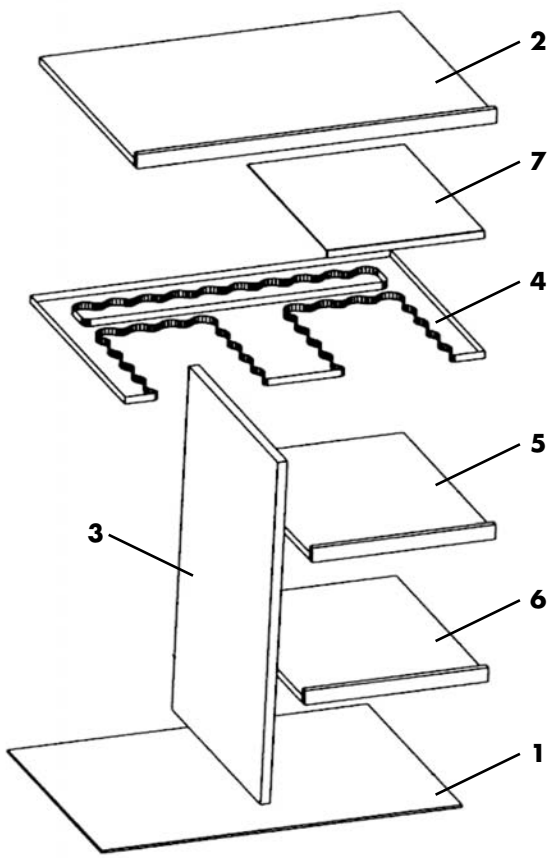

**Holding Bracket**

# INTERIOR SETUP

---

1. Set base in place.
2. Install top shelf.\*
3. Lay center divider upright against side.
4. Install gun rack.\* (Shelf clips should be placed at center divider height).

Two holding brackets provided to support center divider. Insert holding bracket in predrilled holes under gun rack, and slide flat side into shelf bracket strip.

One holding bracket should be placed on the right side of the divider and the other on the left side. Brackets will support center divider and hold it in place.

5. Install side shelf.
6. Install side shelf.  
Adjust shelf clips as needed.  
Side shelves may be installed on either right or left.
7. The #7 shelf fits directly over the gun rack. This allows you to use the rack as a shelf.
  - Converting your combo interior to an all-rifle interior requires removal of shelves 5, 6, & 7.

## **INTERIOR SETUP - some models**

Some models come with the center upright and gun rack already in position.

Simply place the top shelf in position and the side shelves at the desired location.

## DOOR ADJUSTMENT

---

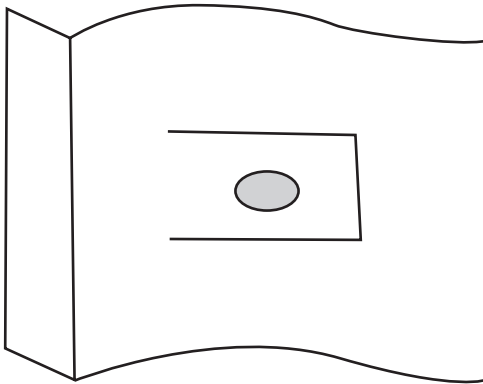

On rear of left door jam, in alignment with the second locking bolt down from the top, there is a U shaped cutout with a hole in the center. Using a Phillips screwdriver, insert in the hole, gently bend the tab, in small increments to tighten door.

# TYPES OF ELECTRONIC LOCKS

---



**LaGard Basic**



**KABA MAS**



**LaGard Access**

# LAGARD BASIC

---

## OPENING THE LOCK

Enter six (6) digit code and turn handle counter-clockwise to unlock safe.

## WRONG TRY PENALTY

- Entry of four consecutive invalid codes starts a 5-minute delay period.
- Key pad will be 'dead' during delay period.
- LED flashes red at 10 second intervals.
- At the end of the delay period, two more incorrect codes will restart the delay.

## LOW BATTERY WARNING

- Repeated beeping during opening indicates a low battery and should be replaced immediately.
- Uses one (1) 9-volt Alkaline Battery.

## CHANGING BATTERY

- Lift the face plate straight up about 1/4" and away from safe door.
- Battery is located in back of face plate.
- Being careful not to pull on the wires connected to the battery connector, remove the old battery.
- Attach new 9-Volt Alkaline Battery to connector and replace face on front of door
- LaGard recommends the use of Energizer or Duracell. The "use date" should be at least five (5) years in the future.

## CHANGING YOUR CODE

### DOOR SHOULD BE OPEN

### DOOR 'MUST' BE IN LOCKED MODE

- Enter six (6) zeros.
- Enter existing six (6) digit code.
- Enter NEW six (6) digit code twice.
- **Invalid Combination Entry** – Lock signals three times and old code is still valid.

***On some models there is a detent release on the bottom of door that must be pushed up to put door into locked mode.***

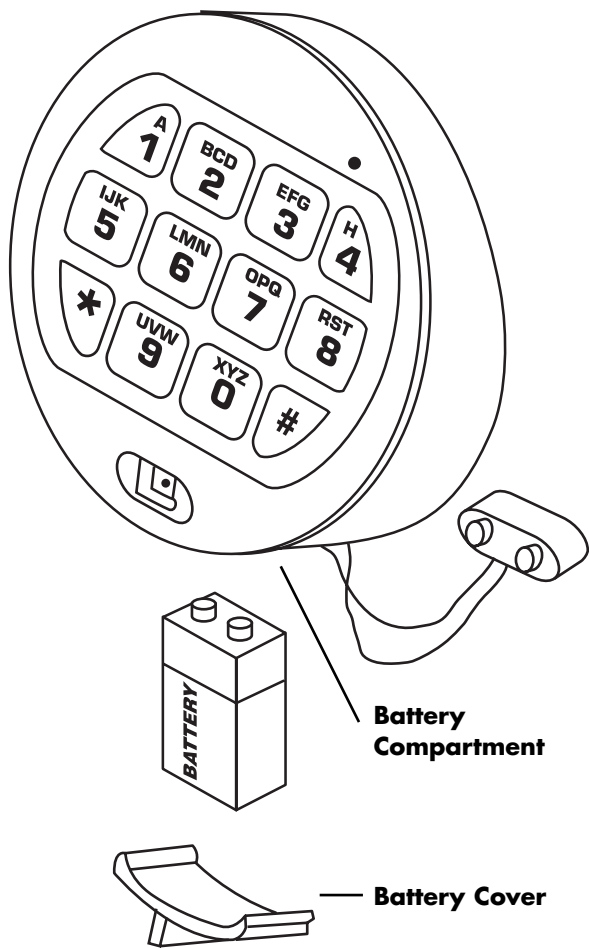

**Battery  
Compartment**

**Battery Cover**

# KABA MAS

---

## OPENING THE LOCK

Enter six (6) digit code and turn handle counter-clockwise to unlock safe.

## TO CANCEL ENTRY

Press \*

## WRONG TRY PENALTY

- Entry of five consecutive invalid codes goes into 3 minute lock-out. Each additional wrong entry adds 3 more minutes.
- Key pad will be 'dead' during lockout period.
- Red LED flashes and beeps during lock-out.

## BOLT END PRESSURE

- Indicated by green flash with beep, followed by maximum of twelve (12) red flashes.
- Turn handle clockwise before all twelve (12) red flashes are displayed, the red flashes will terminate and a green flash with a beep will occur indicating the lock can now be opened.

## CHANGING YOUR CODE

**DOOR SHOULD BE OPEN**

**DOOR 'MUST' BE IN LOCKED MODE**

- Press # key. Press #1, there will be one beep and one flash.
- Enter existing six (6) digit code, there will be one beep and flash.
- Enter New six (6) digit code, there will be one beep and flash.
- Enter New code again, there will be two beeps and flashes.
- Test several times with door open, two beeps and flashes always signal a correct combo.
- If you make a mistake the lock will revert back to old code.

*On some models there is a detent release on the bottom of door that must be pushed up to put door into locked mode.*

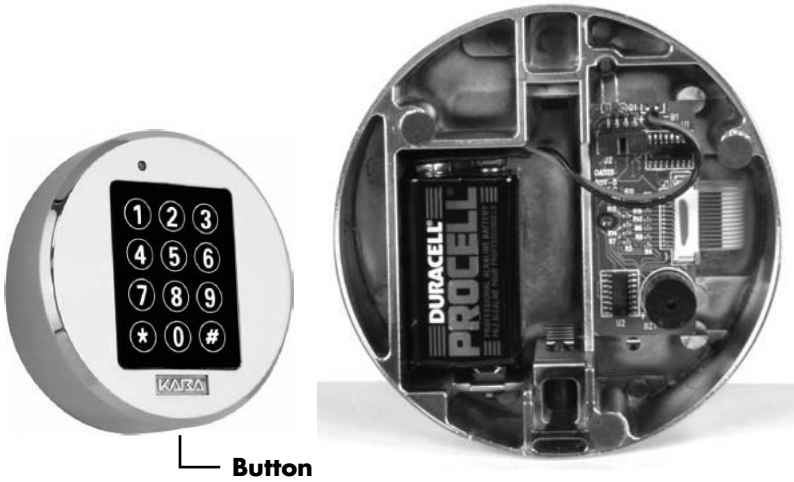

## LOW BATTER INDICATION

Continuous green and red flashes with beeps after lock opens

## CHANGING BATTERIES

- Press button on bottom of keypad, lift off towards the left.
- Being careful not to pull on the wires connected to the battery connector, remove the old battery.
- Attach new 9-Volt Alkaline Battery to connector and replace keypad on to front of safe.
- Kaba Mas recommends the use of Energizer or Duracell. Try to find one with a 'use by' date at least 5 years in the future.

# LAGARD ACCESS

---

## OPENING THE LOCK

Enter the six (6) digit code and turn the handle counter-clockwise to unlock the safe.

## WRONG TRY PENALTY

- Entry of four consecutive invalid codes starts a 5-minute lock-out period.
- Key pad will be 'dead' during lock-out period.
- LED flashes red at 10 second intervals.
- At the end of the lock-out period, two more incorrect codes will restart the lock-out.

## LOW BATTERY WARNING

- Repeated beeping during opening indicates a low battery and should be replaced immediately.
- Uses one (1) 9-volt alkaline battery.

## CHANGING BATTERIES

- Using a ballpoint pen, insert tip into round opening in the base of the handle.
- Lift the battery cover away from the backside of the handle.
- Being careful not to pull on the wires attached to the battery connector, remove the old battery.
- Attach new 9-Volt alkaline battery to connector and replace battery cover.
- LaGard recommends the use of *Energizer*® or *Duracell*® brand batteries with a "use by" date at least five (5) years in the future.

## CHANGING YOUR CODE

### ***DOOR SHOULD BE OPEN DOOR 'MUST' BE IN 'LOCKED' MODE***

- Enter six (6) zeros.
- Enter existing six (6) digit code.
- Enter NEW six (6) digit code twice.
- **Invalid combination entry** – Lock signals three times old code is still valid.

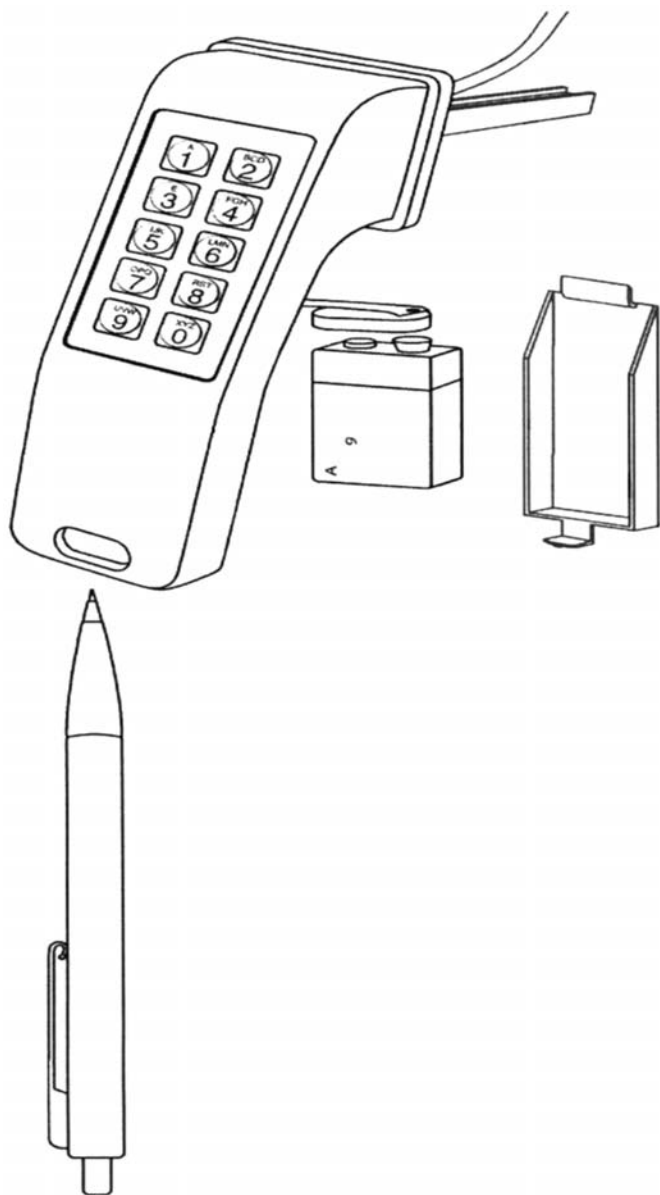

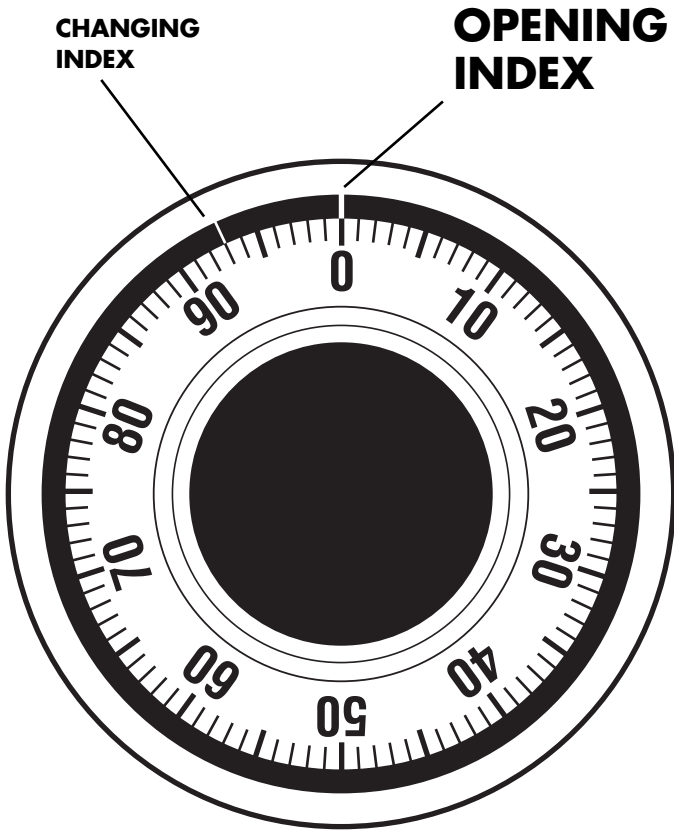

**\* IGNORE CHANGING INDEX**

# USING THE MECHANICAL LOCK

---

**DO NOT SPIN THE DIAL  
TURN SLOWLY**

**USE OPENING INDEX MARK AT TOP OF RING  
(12:00 POSITION)**

Turning dial left (counter-clockwise) stop on first number the 4th time you come to it

Turning dial right (clockwise) stop on second number the 3rd time you come to it

Turning dial to the left stop on third number the 2nd time you come to it

Turn dial slowly to the right, you should feel resistance around zero and the lock should stop turning at about 88-90

Turn handle left or counter-clockwise until safe opens.

---

## WARNING

---

**NEVER LUBRICATE THE LOCK OR DIAL  
WITH ANY TYPE OF LUBRICANT.**

---

## THE KEY LOCKING DIAL

---

The dial has a key feature. This will allow the dial to be locked either in the open mode or locked mode.

Locking the dial at 90, after combination has opened the safe, will prevent anyone from shutting the door and locking it.

Once you close the door and turn the combination, you can then lock the dial in the "0" position to prevent anyone from tampering with the lock.

***Never use the key as the sole means of locking the safe. It is not meant as the primary locking feature.***

# FREQUENTLY ASKED QUESTIONS

---

## **Where is the serial number?**

The serial number is located on the right side of the safe, upper front corner.

## **How do I clean my safe?**

You can use any mild cleaner without abrasives (like *Windex*®).

**Do not use any product containing ammonia.**

## **Can I polish my safe?**

On the gloss models you can use any automotive (abrasive free) wax or glaze.

## **Is my safe water tight?**

No! In a flood, water will enter the safe, so place your safe in a dry location.

## **Is my safe airtight?**

No! Some air will get into your safe, but not enough to live on.

**Never leave unattended children near an open safe!**

## **Do I need a dehumidifier?**

A dehumidifier will help to protect the contents of your safe from a humid environment.

## **Is my safe pre-drilled for a dehumidifier?**

The body is drilled three (3) inches from the bottom slightly off midline on the back side. You will have to continue the hole through the fireboard.

## **Do I need to lubricate my safe?**

Lubricate hinge if needed.

**Never lubricate the lock.**

## **Should my safe be level?**

Yes. This can be done with wood shims available at most lumber or hardware stores. If your safe is on carpet you will probably have to shim the front about 3/8 inch to compensate for the tack strip against the wall.

## **Why do I need to bolt my safe down?**

There are two reasons to bolt your safe down. First, under normal circumstances your safe should never tip over, but earthquakes etc. can surprise us. Second, if your safe is located in the garage, it will stop anyone from backing a truck up and driving away with your safe.

## **How do I bolt it down?**

The floor of the safe is pre-drilled. Place the safe in position, level it, drill right through the pre-drilled holes into the floor. Use either 3/8 or 1/2 inch sleeved anchors that will extend into the concrete 2-3 inches. Be sure to use four bolts to properly secure your safe.

## **My combination quit working, what do I do?**

If your dial has been repeatedly spun, the disks in the lock may have shifted. Most of the time if you drop the middle number by one digit the safe will open. This new number will now be your combination.



## *Certificate of Compliance*

The following Cannon Safe, Inc. security products exceed California Department of Justice "Gun Safe Standards" as per Title 11, Division 1, Chapter 12.6, § 977.50;

- Traditional Series, all models.
- Cannon Series, all models.
- American Eagle Series, all models.

**DO NOT DISCARD THIS CERTIFICATE.  
ATTACH TO YOUR RECEIPT OF PURCHASE.**

**ALL CANNON SAFES ARE  
UL BURGLARY RATED  
TO THE RESIDENTIAL SECURITY  
CONTAINER STANDARD**

# QUICK DRAW GUN RACK



**Firearms Record:**

Pistol  Rifle  shotgun  Serial Number \_\_\_\_\_

Make \_\_\_\_\_ Model \_\_\_\_\_

Caliber/Gauge \_\_\_\_\_ Grips/Stock \_\_\_\_\_

Barrel Length \_\_\_\_\_ Overall Length \_\_\_\_\_ Finish \_\_\_\_\_

Scopes & Sights \_\_\_\_\_

Other Features \_\_\_\_\_

Repairs/Mods/Accessories \_\_\_\_\_

**Record of Purchase:**

Purchase Date \_\_\_\_\_ Cost \_\_\_\_\_ Condition \_\_\_\_\_

Estimated Current Value \_\_\_\_\_

**Record of Sale:**

Date Sold \_\_\_\_\_ Price \_\_\_\_\_ Sold To: \_\_\_\_\_

Registration Information: \_\_\_\_\_

\_\_\_\_\_  
DROS # \_\_\_\_\_

**Firearms Record:**

Pistol  Rifle  shotgun  Serial Number \_\_\_\_\_

Make \_\_\_\_\_ Model \_\_\_\_\_

Caliber/Gauge \_\_\_\_\_ Grips/Stock \_\_\_\_\_

Barrel Length \_\_\_\_\_ Overall Length \_\_\_\_\_ Finish \_\_\_\_\_

Scopes & Sights \_\_\_\_\_

Other Features \_\_\_\_\_

Repairs/Mods/Accessories \_\_\_\_\_

**Record of Purchase:**

Purchase Date \_\_\_\_\_ Cost \_\_\_\_\_ Condition \_\_\_\_\_

Estimated Current Value \_\_\_\_\_

**Record of Sale:**

Date Sold \_\_\_\_\_ Price \_\_\_\_\_ Sold To: \_\_\_\_\_

Registration Information: \_\_\_\_\_

\_\_\_\_\_  
DROS # \_\_\_\_\_



**CANNON SAFE, INC.**  
**216 SOUTH 2ND AVE., BLDG. 932**  
**SAN BERNARDINO, CA 92408**